

HILTI

GX 120-ME

Bedienungsanleitung	de
Operating instructions	en
Mode d'emploi	fr
Manual de instrucciones	es
Istruzioni d'uso	it
Gebbruksaanwijzing	nl
Brugsanvisning	da
Bruksanvisning	no
Bruksanvisning	sv
Käyttöohje	fi
Manual de instruções	pt
Οδηγίες χρήσεως	el
Kullanma Talimatı	tr
Lietošanas pamācība	lv
Instrukcija	lt
Kasutusjuhend	et
사용설명서	ko
操作說明書	zh
دليل الاستعمال	ar



1

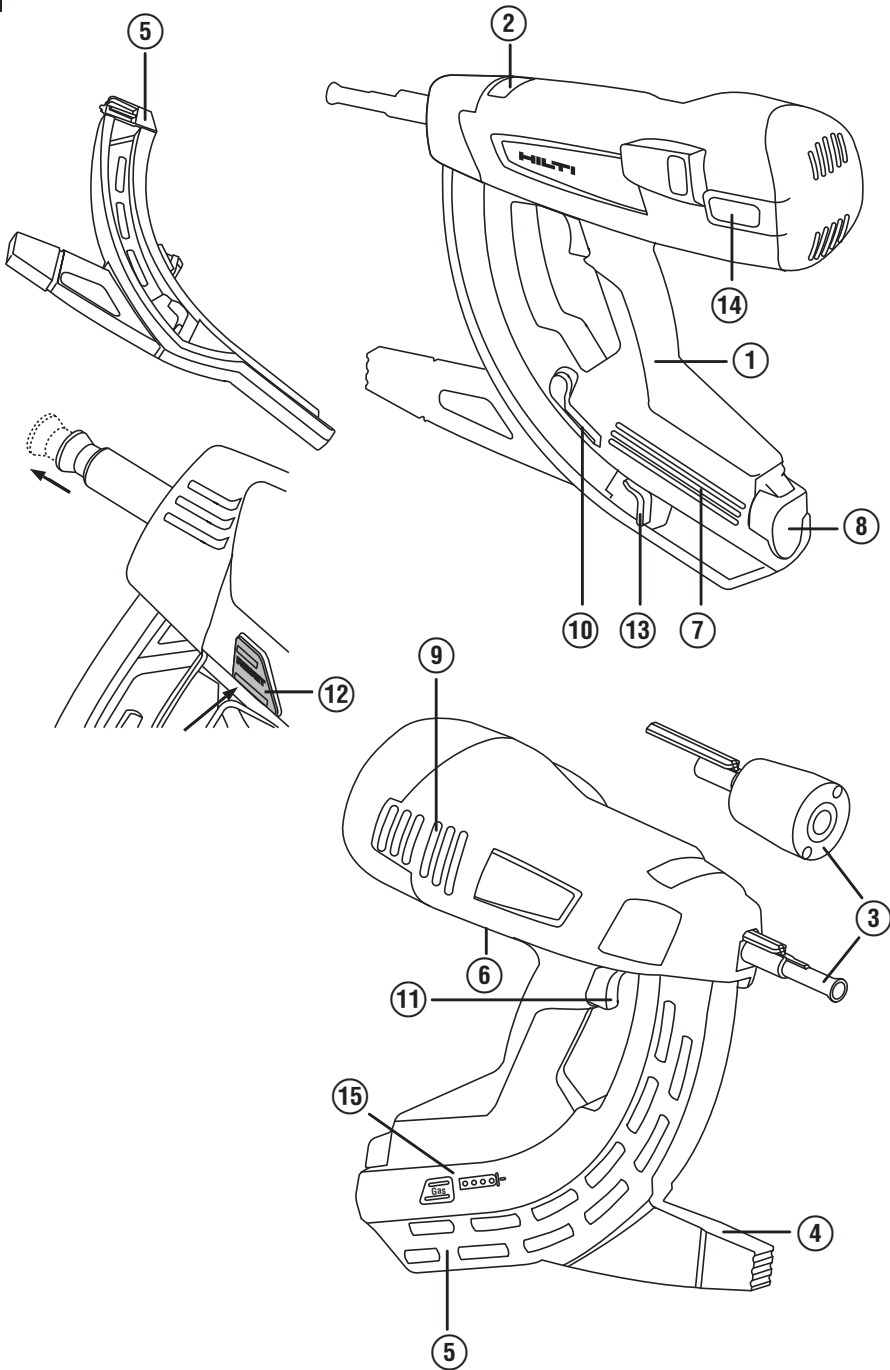

2

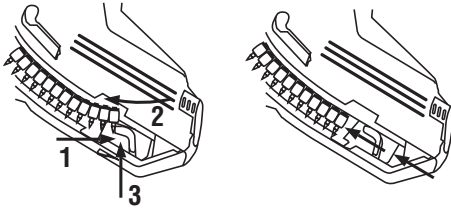

3

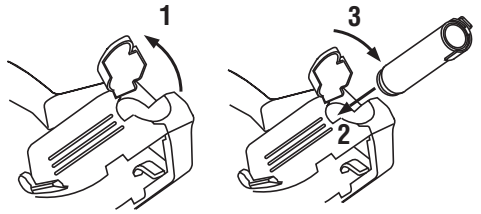

4

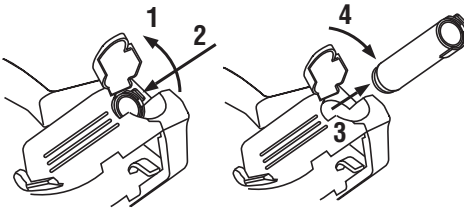

5

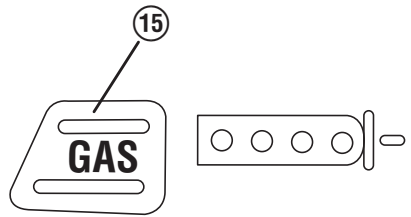

6

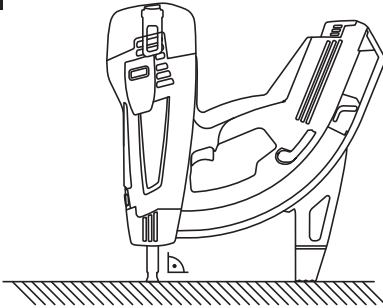

7

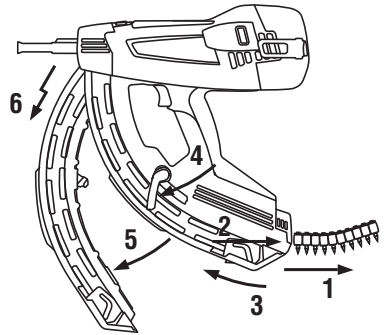

8

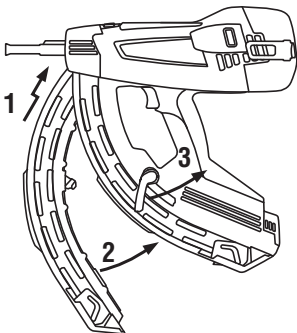

9

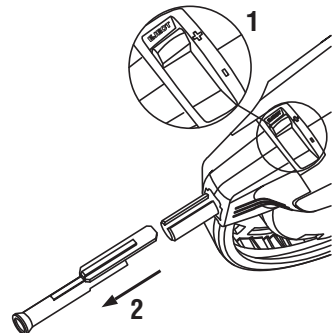

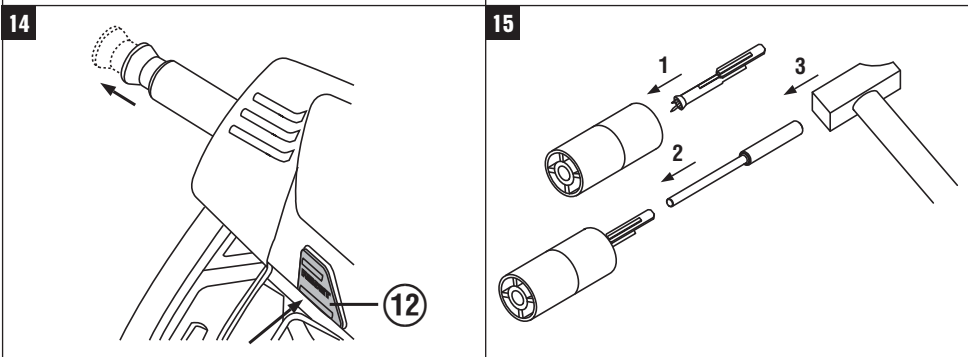
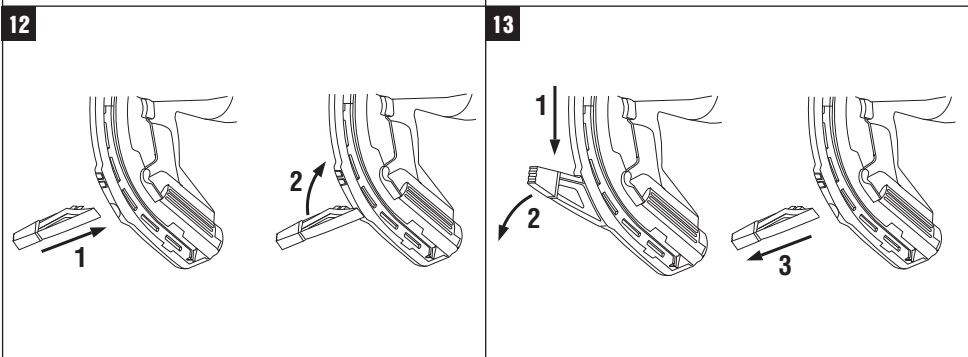
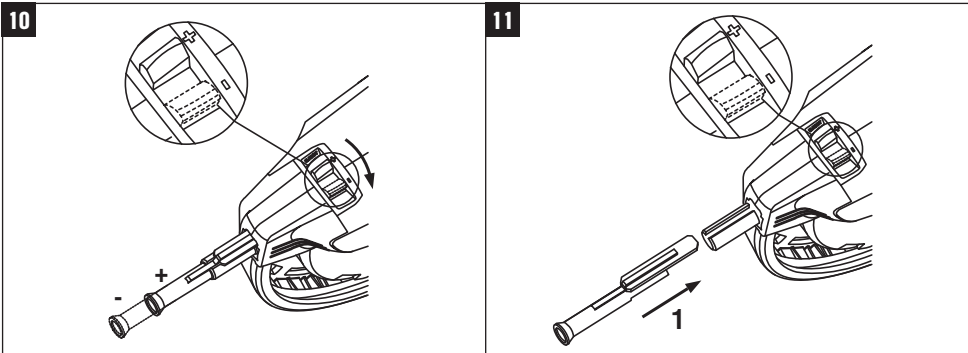

ORIGINAL OPERATING INSTRUCTIONS

GX 120-ME gas-driven fastening tool

en

It is essential that the operating instructions are read before the tool is operated for the first time.

Always keep these operating instructions together with the tool.

Ensure that the operating instructions are with the tool when it is given to other persons.

Contents	Page
1 General information	14
2 Description	15
3 Accessories, consumables	15
4 Technical data	16
5 Safety instructions	17
6 Before use	19
7 Operation	19
8 Care and maintenance	21
9 Troubleshooting	22
10 Disposal	25
11 Manufacturer's warranty - tools	25
12 EC declaration of conformity (original)	26
13 Health and safety of the operator	26

1 These numbers refer to the corresponding illustrations. The illustrations can be found on the fold-out cover pages. Keep these pages open while studying the operating instructions.

In these operating instructions, the designation "the tool" always refers to the GX 120-ME gas-driven fastening tool.

Parts, operating controls and indicators 1

- 1 Grip
- 2 Lockbutton and power regulator
- 3 Nosepieces
- 4 Support leg
- 5 Magazine (20 nails or 40 nails)
- 6 Type identification plate
- 7 Gas can compartment
- 8 Gas can compartment cover
- 9 Ventilation slots
- 10 Locking lever
- 11 Trigger
- 12 Reset button
- 13 Nail pusher
- 14 Belt hook
- 15 Gas level indicator

1 General information

1.1 Safety notices and their meaning

DANGER

Draws attention to imminent danger that will lead to serious bodily injury or fatality.

WARNING

Draws attention to a potentially dangerous situation that could lead to serious personal injury or fatality.

CAUTION

Draws attention to a potentially dangerous situation that could lead to slight personal injury or damage to the equipment or other property.

NOTE

Draws attention to an instruction or other useful information.

1.2 Explanation of the pictograms and other information

Warning signs



General warning



Warning: hot surface

Obligation signs



Wear eye protection.



Wear a hard hat.



Wear ear protection.



Wear protective gloves.

Symbols



Read the operating instructions before use.

Location of identification data on the tool

The type designation and serial number can be found on the type identification plate on the tool. Make a note of this data in your operating instructions and always refer to it when making an enquiry to your Hilti representative or service department.

Type: _____

Generation: 01 _____

Serial no.: _____

en

2 Description

2.1 Use of the product as directed

The tool is designed for driving specially manufactured nails (fasteners) into concrete, steel and other materials suitable for the direct fastening technique (please refer to the Fastening Technology Manual).

The tool is designed for professional use in fastening applications in the drywall installation trade and other building trades where fasteners are driven into concrete, steel, sand-lime block, concrete block and rendered masonry.

The tool, gas can and fasteners form a single technical unit. This means that the tool can achieve optimum fastening performance only when used in conjunction

with the Hilti fasteners and gas cans specially designed and manufactured for it. The fastening and application recommendations given by Hilti apply only when these conditions are observed.

The tool is for hand-held use only.

The tool may be operated, serviced and repaired only by trained personnel. This personnel must be informed of any special hazards that may be encountered.

Modification of the tool is not permissible.

Observe the information printed in the operating instructions concerning operation, care and maintenance.

The tool and its ancillary equipment may present hazards when used incorrectly by untrained personnel or when used not as directed.

3 Accessories, consumables

Designation	Description
Gas can	GC 21/ GC 22
Nosepiece	X-120 ME TN
Additional nosepieces	X-120 WH (washers)
Magazine	X-120 GM 40/ X-120 GM 20
Support leg	X-120 SL
Set of pin punches	X-120 NP set
Tool clip	X-120 TS

Nails	Length	In magazine strips of	For use on (please contact Hilti for detailed information)
X-EGN 14MX	14 mm (1/2")	10	Steel
X-EGN 18MX	18 mm (11/16")	10	Hard concrete / precast concrete / steel
X-EGN 20MX	20 mm (3/4")	10	Hard concrete / precast concrete / steel

Nails	Length	In magazine strips of	For use on (please contact Hilti for detailed information)
X-EGN 24MX	24 mm (¹⁵ / ₁₆ "	10	Hard concrete / precast concrete / steel
X-GN 20 MX	20 mm (³ / ₄ "	10	Concrete / rendered masonry (1cm / ³ / ₈ ") / sand-lime block / concrete block
X-GN 27 MX	27 mm (1")	10	Concrete / rendered masonry (1cm / ³ / ₈ ") / sand-lime block / concrete block
X-GN 32 MX	32 mm (1 1/4")	10	Concrete / rendered masonry (1cm / ³ / ₈ ") / sand-lime block / concrete block
X-GN 39 MX	39 mm (1 9/16")	10	Concrete / rendered masonry (1cm / ³ / ₈ ") / sand-lime block / concrete block
X-GPN 37 MX	37 mm (1 1/2")	10	Sheet steel / thin steel

Other fasteners	Designation	Sizes
Rings and clips for pipes and conduits	X-FB; X-DFB X-BX; X-EMTC X-EMTSC X-EKS; X-EKSC	8...40 mm ³ / ₈ "-1" 1/2"-1" 16...40 mm
Holder for clips and cables	X-EKB	Up to 16 cables
Holder for cable ties	X-ECT	
Hanger for threaded rods and wire	X-HS X-CC	M4-M8 W6 thread
Universal plastic washer	X-ET	

4 Technical data

Right of technical changes reserved.

NOTE

The tool is equipped with a transmitter module.

Tool with magazine

Weight	3.8 kg (8.41 lbs)
Dimensions (L x W x H)	431 mm X 134 mm X 392 mm (17" x 5 1/4" x 15 1/2")
Nail length	Max. 39 mm (max. 1 9/16")
Nail diameter	∅ 3 mm (∅ 0.118 in) / ∅ 2.6 mm (∅ 0.102 in)
Magazine capacity	40 + 2 nails or 20 + 2 nails
Contact movement	40 mm (1 9/16")
Operating temperature / ambient temperature with GC 21 gas can	-5...+45°C (23 °F to 113 °F)
Operating temperature / ambient temperature with GC 22 gas can	-10...+45°C (14°F to 113°F)

Maximum fastener driving rate	1,200/h
Energy-equivalent acceleration, $a_{hw, RMS(3)}$	Recoil: Applicable to 1 mm sheet metal on B45 concrete: 4.04 m/s ²

Gas can

Capacity	1 can for 750 nails
Recommended transport and storage temperature	+5...+25°C (41°F to 77°F)
Substances contained	Isobutane, propene
Gas can	Not refillable
The gas can is pressurized. Protect the gas can from the heat of the sun.	Never expose the gas can to temperatures over 50°C (122°F).

en

5 Safety instructions

5.1 Basic information concerning safety

In addition to the information relevant to safety given in each of the sections of these operating instructions, the following points must be strictly observed at all times.

5.1.1 Personal safety

- Stay alert, watch what you are doing and use common sense when operating a direct fastening tool. Do not use a tool while you are tired or under the influence of drugs, alcohol or medication.** A moment of inattention while operating tools may result in serious personal injury.
- Avoid unfavorable body positions. Make sure you work from a safe stance and stay in balance at all times.**
- Never point the tool toward yourself or other persons.**
- Never press the nosepiece of the tool against your hand or against any other part of your body (or other person's hand or part of their body).**
- Keep other persons, especially children, away from the area in which the work is being carried out.**

5.1.2 Fastening tool use and care

- Use the right tool for the job. Do not use the tool for purposes for which it was not intended. Use it only as directed and when in faultless condition.**
- Press the tool against the working surface at right angles.**
- Never leave a loaded tool unattended.**
- Remove the gas can from the tool before transporting the tool.**
- Always unload the tool (remove the gas can and fasteners) before cleaning, before carrying out care and maintenance, before work breaks and before storing the tool.**
- When not in use, tools must be unloaded and stored in a dry place, locked up or out of reach of children.**
- Check the tool or machine and its accessories for damage and ensure that they function faultlessly**

and as intended. Check that moving parts function correctly without sticking and that no parts are damaged. All parts must be fitted correctly and fulfill all conditions necessary for correct operation of the tool. Damaged guards, safety devices and other parts must be repaired or replaced properly at a Hilti service center unless otherwise indicated in the operating instructions.

- Keep the arms slightly bent while operating the tool (do not straighten the arms).**
- Pull the trigger only when the tool is pressed against the working surface at right angles.**
- Always hold the tool securely and at right angles to the working surface when driving a fastener. This will help to prevent fasteners being deflected by the working surface.**
- Never redrive a fastener. This may cause the fastener to break and the tool may jam.**
- Never drive fasteners into existing holes unless this is recommended by Hilti.**
- Always observe the application guidelines.**

5.1.3 Work area safety



- Ensure that the workplace is well lit.**
- Operate the tool only in well-ventilated working areas.**
- Do not attempt to drive fasteners into unsuitable materials.** Materials that are too hard, e.g. welded steel and cast iron. Materials that are too soft, e.g. wood and drywall panel (gypsum board). Materials that are too brittle, e.g. glass and ceramic tiles. Driving a fastener into these materials may cause the fastener to break, shatter or to be driven right through.
- Before driving fasteners, check that no one is present immediately behind or below the working surface.**

- e) **Keep the workplace tidy. Objects which could cause injury should be removed from the working area.** Untidiness at the workplace can lead to accidents.
- f) **Keep the grips dry, clean and free from oil and grease.**
- g) **Wear non-skid shoes.**
- h) **Take the influences of the surrounding area into account. Do not expose the tool to rain or snow and do not use it in damp or wet conditions. Do not use the tool where there is a risk of fire or explosion.**

5.1.4 Mechanical hazards



- a) **Select the correct fastener guide and fastener combination for the job on hand.** Failure to use the correct combination of these items may result in damage to the tool and/or unsatisfactory fastening quality.
- b) **Use only fasteners of a type approved for use with the tool.**
- c) **Never fill the magazine with fasteners unless it is correctly fitted to the tool. The fasteners could be ejected uncontrollably.**

5.1.5 Thermal hazards



- a) **If the tool has overheated, allow it to cool down. Do not exceed the recommended fastener driving rate.**
- b) **Always wear gloves if the tool has to be dismantled for cleaning or maintenance before it has been allowed to cool down.**

5.1.6 Gasses

Liquid gas under pressure:

Observe the hazard warnings and first-aid instructions printed on the gas can and in the instructions for use.

The gas is extremely flammable (contains: isobutane, propene).

Refilling the gas can is not permissible.

- a) **Do not use damaged gas cans.**
- b) **Do not attempt to force the gas can open. Do not incinerate or crush the can and do not attempt to reuse it for any other purpose.**
- c) **Never spray the gas toward persons or other living beings.**
- d) **Keep the gas away from all sources of ignition such as naked flames, sparks, pilot lights, static discharge and very warm surfaces.**
- e) **Do not smoke while using the tool.**

5.1.6.1 Storage

- a) **Do not store gas cans in inhabited rooms or in rooms connected to inhabited rooms.**
- b) **Store the gas cans in a dry, well-ventilated place.**
- c) **Store the gas cans out of reach of children.**
- d) **Do not expose gas cans to direct sunlight or temperatures above 50°C (122°F).**
- e) **Recommended storage temperature: 5°C to 25°C (41°F to 77°F).**

5.1.6.2 First aid

Read the material safety data sheet for information about use, care and maintenance and first-aid measures.

- a) **Direct skin contact with the liquid gas may cause frostbite or a serious freezing injury similar to a burn.**
- b) **In case of inhalation of the gas: The person affected should be taken into the open air and brought into a comfortable position.**
- c) **In case of unconsciousness: Bring the person affected into a secure recovery position. Should the person stop breathing, apply artificial respiration and supply oxygen if necessary.**
- d) **In case of gas contact with the eyes: Rinse the open eyes under running water for one minute.**
- e) **In case of gas contact with the skin: Wash the contact surface carefully with warm water and soap. Subsequently apply a skin cream.**
- f) **Consult a doctor if necessary.**

5.1.7 Protective device

Never use the tool if the applicable safety devices have been damaged or removed.

6 Before use



NOTE

Read the operating instructions before using the tool.

6.1 Inserting nails 2

1. Pull the nail pusher back until it engages.
NOTE The nail pusher must engage in this position.
2. Slide the nails into the magazine (maximum of 4 strips of 10 nails).

3. Release the nail pusher and allow it to slide forward slowly.

6.2 Inserting the gas can 3

1. Open the cover.
2. Push the gas can into the gas can compartment, valve first, until the clip engages.
3. Close the cover.
4. Press the tool against the working surface 3 times without pulling the trigger.

6.3 Removing the gas can 4

1. Open the cover of the gas can compartment.
2. Press the can retaining clip.
3. Remove the gas can.
4. Close the cover of the gas can compartment.

6.4 Checking the gas can 5

NOTE

- To check the gas level in the can, press the button marked GAS. When doing so, take care to ensure that the tool is not pressed against the working surface.
- Even when the indicator shows "empty", a small quantity of gas, for technical reasons, still remains in the can.

4 LEDs light green constantly.	The gas can is full.
2 LEDs light green constantly.	The gas can is half full.
1 LED blinks green.	The gas can is almost empty. The gas can should be changed.
1 LED lights red constantly.	The gas can is empty, no gas can fitted or wrong gas can fitted.

7 Operation



NOTE

When holding the tool steady with the second hand, the hand must be positioned in such a way that no ventilation slots or openings are covered.

CAUTION

Never redrive a fastener. This may cause the fastener to break and the tool may jam.

WARNING

Material may splinter when the fastener is driven or fragments of the magazine strip may fly off. Splintering material presents a risk of injury to the eyes and body. **The user of the tool and all persons in the vicinity must wear eye protection and a hard hat.**

CAUTION

The fastener is driven by the energy released on ignition of a gas-air mixture. Exposure to noise can cause hearing loss. **The operator and bystanders must wear ear protectors.**

WARNING

Never make the tool ready to fire by pressing it against a part of the body (e.g. the hand). When the tool is ready to fire, fasteners could be driven inadvertently into parts of the body. **Never press the tool against parts of the body.**

WARNING

Never pull the tool nosepiece back by the fastening component inserted in it (e.g. soft washer, pipe ring or clip etc.). This presents an increased risk of accident.

WARNING

The tool must always be unloaded before changing the magazine and before carrying out cleaning or maintenance (see section "Unloading the tool").

WARNING

Parts of the tool outside the grip area may get hot when fasteners are driven at a rapid rate over a long period of time. **Wear protective gloves.**

7.1 Operation 6

NOTE

It is possible to drive a fastener only when more than 3 nails are in the magazine.

1. Position the nose of the tool at right angles to the working surface and then press it against the working surface as far as it will go.
2. Drive the fastener by pulling the trigger.
3. After driving the fastener, lift the tool away completely from the working surface.

7.1.1 Using pipe rings and other fasteners

If you wish to use pipe rings and other types of fastener, push the plastic part of the fastener into the tool nosepiece.

7.2 Gas level indicator 5

Please refer to section 6.4 "Checking the gas can (for 2 seconds)".

7.3 Fitting and removing the magazine

7.3.1 Removing the magazine 7

1. Pull the nail pusher back until it engages.
NOTE The nail pusher must engage in this position.
2. Remove all fasteners from the magazine.
3. Release the nail pusher and allow it to slide forward slowly.
4. Push the locking lever down toward the magazine.
5. Pivot the magazine forward away from the tool.
6. Disengage the magazine from the tool.

7.3.2 Fitting the magazine 8

1. Engage the magazine with the tool.
NOTE The locking lever must be in the open position.
2. Guide the magazine toward the tool until the shaped parts fit together.
3. Close the locking lever and check that it engages.

7.4 Nosepiece

7.4.1 Removing the nosepiece 9

1. Set the power regulator to "Eject".
2. Remove the nosepiece.

7.4.2 Settings at the nosepiece

NOTE

When the power regulator is set to "+", the nosepiece is set to the standard fastener driving depth.

NOTE

When the power regulator is set to "-", the nosepiece is set to the reduced fastener driving depth.

NOTE

If the nail is still driven too deeply when the power regulator is set to "-", it may be necessary to use a longer nail.

7.4.2.1 Setting the standard fastener driving depth 10

Set the power regulator to "+".

7.4.2.2 Setting the reduced fastener driving depth 10

NOTE

This setting is suitable for fastening thin sheet metal to soft materials (e.g. young / green concrete).

Set the power regulator to "-".

7.4.3 Fitting the tool nosepiece 11

WARNING

Check to ensure that the tool is not loaded. The tool could be made ready to fire inadvertently by pressing the nosepiece in by hand.

1. Align the nosepiece with the slot in the tool.
2. Push the nosepiece onto the tool.
3. While holding the nosepiece with the hand, press the tool against the working surface until the nosepiece engages in position.

7.5 Support leg

7.5.1 Fitting the support leg 12

1. Push the support leg into the slot in the magazine at right angles.
2. Turn the support leg through 90° and engage it in position.

7.5.2 Removing the support leg 13

1. Release the support leg by pressing the spring catch.
2. Turn the support leg through 90°.
3. Pull the support leg away from the magazine at right angles.

7.6 Bringing the piston into the correct position 14

NOTE

The piston is incorrectly positioned when the tool nosepiece has not extended to its original position after the tool is lifted away from the working surface and the reset button is projecting.

The piston can be returned to the correct position by pressing the reset button. Fasteners can then be driven. In exceptional cases, the tool may fire without driving a fastener when the tool is operated for the first time after resetting the piston.

Press the reset button.

7.7 Removing a jammed fastener

1. Remove the magazine.
2. Remove the nosepiece.
3. Fit the nosepiece into the support supplied.
4. Use the pin punch to remove the fastener.

7.8 Unloading the tool

1. Open the cover of the gas can compartment.
2. Press the can retaining clip and remove the gas can.
3. Close the cover of the gas can compartment.
4. Pull the nail pusher back until it engages.
NOTE The nail pusher must engage in this position.
5. Remove the fasteners from the magazine.
6. Release the nail pusher in the magazine and allow it to slide forward slowly.

en

7.9 Application guidelines

NOTE

For detailed information, please ask the Hilti marketing organization in your country for a copy of the Hilti Fastening Technology Manual or the applicable national regulations.

Concrete

A = min. distance from edge = 70 mm (2¾")

B = min. fastener center spacing = 80 mm (3⅛")

C = min. base material thickness = 100 mm (4")

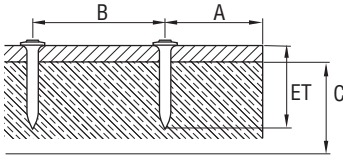

Steel

A = min. distance from edge = 15 mm (⅝")

B = min. fastener center spacing = 20 mm (¾")

C = min. base material thickness = 4 mm (⅝/32")

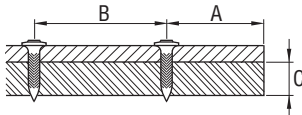

7.10 Belt hook

The belt hook can be used to attach the tool in position 1 to a belt or in position 2 to a ladder or scaffold.

8 Care and maintenance



WARNING

The tool must be unloaded (gas can and fasteners removed from the tool) before carrying out cleaning or maintenance.

CAUTION

The tool may get hot during use. You could burn your hands. **Wear protective gloves before carrying out care and maintenance. Allow the tool to cool down.**

8.1 Care of the tool 

CAUTION

Take care not to damage the piston detector, nail detector and magazine detector.

1. Remove plastic debris from the nosepiece at regular intervals.
2. Never operate the tool when the ventilation slots are blocked. Clean the ventilation slots carefully using a dry brush.
3. Do not permit foreign objects to enter the interior of the tool.
4. Clean the outside of the tool at regular intervals with a slightly damp cloth.
5. Do not use a spray, steam pressure cleaning equipment or running water for cleaning.

6. Always keep the grip surfaces of the tool free from oil and grease.
7. Do not use cleaning agents which contain silicone.
8. Do not use Hilti spray or similar lubricants or cleaning agents.

8.2 Maintenance

Check all external parts of the tool for damage at regular intervals and check that all controls operate faultlessly. Do not operate the tool if parts are damaged or when the controls do not function faultlessly. Have the tool repaired by Hilti Service.

8.3 Checking the tool after care and maintenance

After cleaning or servicing, check that the power regulator is correctly set (standard setting "+") before inserting the gas can.

9 Troubleshooting

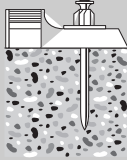
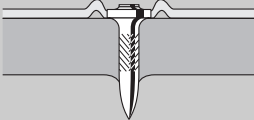
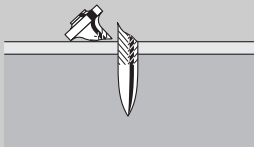

WARNING

The tool must be unloaded (gas can and fasteners removed from the tool) before carrying out cleaning or maintenance.

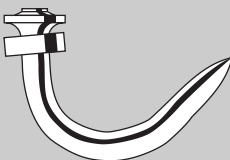
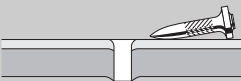
Fault	Possible cause	Remedy
Fastener head stand-off is frequently too high. 	The power regulator is set to "-".	Set the power regulator to "+".
	The fastener used is too long.	Use a shorter fastener.
	The base material is too hard.	Use a DX fastening tool.
	The intake/exhaust valve is dirty or covered over.	Clean the tool and pay attention to the hand position. Contact Hilti if the problem persists.
The fastener is frequently driven too deeply (punches through) and/or the ring or clip breaks. 	Driving power is too high.	Set the power regulator to "-".
	The fastener is too short.	Use a longer fastener.
Fastener breakage. 	The power regulator is set to "-".	Set the power regulator to "+".
	The fastener used is too long.	Use a shorter fastener.
	The base material is too hard.	Use a DX fastening tool.
	The tool is pressed against the surface at an angle.	Hold the tool at right angles to the working surface. Use the support leg. See section: 7.5 Support leg

Fault	Possible cause	Remedy
<p>Fasteners are bent.</p> 	<p>The power regulator is set to “-”.</p> <hr/> <p>The fastener used is too long.</p> <hr/> <p>The tool is pressed against the surface at an angle.</p>	<p>Set the power regulator to “+”.</p> <hr/> <p>Use a shorter fastener.</p> <hr/> <p>Hold the tool at right angles to the working surface. Use the support leg. See section: 7.5 Support leg</p>
<p>Fastener doesn't hold in steel.</p> 	<p>The base material is not thick enough (less than 4 mm).</p>	<p>Use a different fastening technique.</p>
<p>Gas can doesn't last for the whole box of fasteners.</p>	<p>Frequently pressing the tool against the working surface without pulling the trigger causes increased gas consumption.</p>	<p>Avoid pressing the tool against the working surface without pulling the trigger.</p>
<p>The tool remains compressed (does not extend when pressure is released).</p>	<p>The piston is incorrectly positioned.</p>	<p>Press the reset button. See section: 7.6 Bringing the piston into the correct position 14</p>
	<p>The nail detector is jammed; The reset button still projects after it has been pressed (white edge still visible).</p>	<p>Remove the gas can and the magazine from the tool and remove any dirt or debris from the nail detector.</p>
	<p>A fastener is jammed in the tool.</p>	<p>Remove the magazine and the tool nosepiece. Fit the tool nosepiece into the support supplied and use the pin punch to remove the fastener. CAUTION Do not damage the tool nosepiece. See section: 7.7 Removing a jammed fastener 15 See section: 7.3.1 Removing the magazine 7 See section: 7.4.1 Removing the nosepiece 9 See section: 7.8 Unloading the tool Contact Hilti if the problem persists.</p>
<p>Fastener driving failure rate too high.</p>	<p>The tool is pressed against the surface at an angle.</p>	<p>Hold the tool at right angles to the working surface. Use the support leg. See section: 7.5 Support leg</p>
	<p>Wrong type of nail used.</p>	<p>Use X-GHP nails if necessary.</p>
	<p>The base material is too hard.</p>	<p>Use a DX fastening tool.</p>
<p>The tool doesn't fire.</p>	<p>The nail pusher is in the rearmost position.</p>	<p>Release the nail pusher. See section: 7.3 Fitting and removing the magazine</p>
	<p>Insufficient number of fasteners in the magazine (2 or less).</p>	<p>Reload fasteners.</p>
	<p>Fastener feed malfunction.</p>	<p>Use a different strip of fasteners (strip is possibly damaged). Clean the magazine.</p>

Fault	Possible cause	Remedy
The tool doesn't fire.	The gas can is empty.	Check the gas level by pressing the button marked GAS. If only 1 LED lights red constantly, the gas can is empty. Fit a new gas can. See section: 7.2 Gas level indicator.
	No gas can fitted or wrong type of gas can fitted to the tool.	Open the gas can compartment cover and check the contents. If a gas can is present in the tool, press the button marked GAS. If 1 LED lights red constantly, the wrong type of gas can has been inserted in the tool. Insert the correct type of gas can. See section: 7.2 Gas level indicator.
	New gas can fitted, but the tool has not been pressed against the working surface 3 times without pulling the trigger.	Press the tool against the working surface 3 times without pulling the trigger.
	Foreign object in the tool nosepiece section.	Remove the magazine and nosepiece and then remove the foreign object from the tool. See section: 7.3.1 Removing the magazine 7 See section: 7.4.1 Removing the nosepiece 9
	The tool is too hot.	Allow the tool to cool down. Contact Hilti if the problem persists.
When hot, the tool doesn't fire after a pause between use.	The fastener driving rate was considerably higher than 1200 per hour and the gas can is almost empty.	Remove the gas can and then refit it. Then press the tool against the working surface 3 times without firing it. Check the gas level indicator. If the LED lights red constantly, the gas can is empty. Fit a new gas can. Allow the tool to cool down. Observe the maximum fastener driving rate (1200 per hour). Contact Hilti if the problem persists.
The tool doesn't fire or fires sporadically.	Operation outside the limits of the permissible ambient conditions.	If possible, take measures to ensure that the ambient conditions in the working environment remain within the permissible limits. Use a different fastening technique.
	The gas can is not at the operating temperature.	Bring the gas can to the operating temperature (-5°C to 45°C with GC 21, -10°C to 45°C with GC 22).
	Gas bubbles have formed in the gas injection system.	Remove the gas can and then refit it.
	The tool is not lifted away completely from the working surface.	Take care to ensure that the tool is lifted away completely from the working surface after driving each fastener.

Fault	Possible cause	Remedy
Fastener cannot be removed from nosepiece.	A fastener is jammed in the tool nosepiece.	Remove the tool nosepiece from the tool. Fit the tool nosepiece into the support supplied and use the pin punch to remove the fastener. CAUTION Do not damage the tool nosepiece. See section: 7.4.1 Removing the nosepiece  See section: 7.7 Removing a jammed fastener 
Pipe rings and other fasteners cannot be inserted in the tool nosepiece.	Fragments of the magazine strip are lodged in the tool nosepiece.	Remove the fragments of the magazine strip from the tool nosepiece.

10 Disposal



Most of the materials from which Hilti tools or appliances are manufactured can be recycled. The materials must be correctly separated before they can be recycled. In many countries, Hilti has already made arrangements for taking back old tools and appliances for recycling. Ask Hilti customer service or your Hilti representative for further information. If you wish to bring the tool to a materials separation facility yourself: Regional and international directives and regulations must be observed.

11 Manufacturer's warranty - tools

Hilti warrants that the tool supplied is free of defects in material and workmanship. This warranty is valid so long as the tool is operated and handled correctly, cleaned and serviced properly and in accordance with the Hilti Operating Instructions, and the technical system is maintained. This means that only original Hilti consumables, components and spare parts may be used in the tool.

This warranty provides the free-of-charge repair or replacement of defective parts only over the entire lifespan of the tool. Parts requiring repair or replacement as a result of normal wear and tear are not covered by this warranty.

Additional claims are excluded, unless stringent national rules prohibit such exclusion. In particular, Hilti is not obligated for direct, indirect, incidental or con-

sequential damages, losses or expenses in connection with, or by reason of, the use of, or inability to use the tool for any purpose. Implied warranties of merchantability or fitness for a particular purpose are specifically excluded.

For repair or replacement, send the tool or related parts immediately upon discovery of the defect to the address of the local Hilti marketing organization provided.

This constitutes Hilti's entire obligation with regard to warranty and supersedes all prior or contemporaneous comments and oral or written agreements concerning warranties.

NOTE

Observe the gas can expiry date printed on the edge of the can.

12 EC declaration of conformity (original)

Designation:	Gas-driven fastening tool
Type:	GX 120-ME
Generation:	01
Year of design:	2007

Hilti Corporation, Feldkircherstrasse 100,
FL-9494 Schaan



Norbert Wohlwend
Head of Quality & Processes Management
BU Direct Fastening
04/2013

Tassilo Deinzer
Head of BU Direct Fastening
BU Direct Fastening
04/2013

Technical documentation filed at:

Hilti Entwicklungsgesellschaft mbH
Zulassung Elektrowerkzeuge
Hiltistrasse 6
86916 Kaufering
Deutschland

We declare, on our sole responsibility, that this product complies with the following directives and standards: 75/324/EEC, 91/155/EEC, 64/548/EEC, EN ISO 12100, EN 13752-1:2008-12, EN 50081-2, EN 1127-1, EN 417, ISO 8662-11 AMD 1:2001-12, EN 792-13:A1:2008-09, EN 60529:2000-09, 64/548/EEC, EN 55011:1998+A1:1999, CISPR 11:2003, A1:2004, IEC 61000-6-2:2005, EN 61000-6-2:2001, IS1:2005, IEC 61000-6-3:1996, EN 61000-6-3:2001, IEC 61000-4-2:1995, IEC 61000-4-3:2006, IEC 61000-4-8:1993: A1:2000, 2006/42/EC, 2011/65/EU.

13 Health and safety of the operator

13.1 Noise information

Gas-actuated fastening tool

Type	GX 120-ME
Model	Series
Caliber	GC 22
Power regulation	+
Application	Fastening 1 mm sheet metal to concrete (C40) with the X-ECT

Declared measured values of noise characteristics according to 2006/42/EC Machinery Directive in conjunction with DIN EN 15895

Noise (power) level, $L_{WA}, 1s^1$	106 dB (A)
Emission sound pressure level at the workplace, $L_{pA}, 1s^2$	102 dB (A)
Peak sound pressure emission level, $L_{pC}, peak^3$	137 dB (C)
1 ± 2 dB (A) 2 ± 2 dB (A) 3 ± 2 dB (C)	

Operation and set-up conditions: Set-up and operation of the pin driver in accordance with E DIN EN 15895-1 in the semi-anechoic test room of Müller-BBM GmbH. The ambient conditions in the test room conform to DIN EN ISO 3745.

Testing procedure: Enveloping surface method in anechoic room on reflective surface area in accordance with E DIN EN 15895, DIN EN ISO 3745 and DIN EN ISO 11201.

NOTE The noise emissions measured and the associated measurement uncertainty represent the upper limit for the noise values to be expected during the measurements.

Variations in operating conditions may cause deviations from these emission values.

14. FCC statement

This device complies with Part 15 of the FCC Rules and to RSS-210 of Canada.

Operation is subject to the following two conditions:

- (1) this device may not cause harmful interference, and
- (2) this device must accept any interference received, including interference that may cause undesired operation.



Hilti Corporation

LI-9494 Schaan

Tel.: +423 / 234 21 11

Fax: +423 / 234 29 65

www.hilti.com

Hilti = registered trademark of Hilti Corp., Schaan

W 3410 | 1013 | 2-Pos. 1 | 1

Printed in Germany © 2013

Right of technical and programme changes reserved S. E. & O.

39199 / A3



39199